

## PERIFLO PERISTALTIC PUMP MODELS: CT16 / CT19

# INSTRUCTION MANUAL

### EQUIPMENT IDENTIFICATION RECORD

PUMP MODEL NO: \_\_\_\_\_ PUMP S/N: \_\_\_\_\_

CUSTOMER: \_\_\_\_\_ ORDER NO: \_\_\_\_\_

JOB NO: \_\_\_\_\_ TAG NO: \_\_\_\_\_

HOSE MATERIAL: \_\_\_\_\_ MOUNTING POSITION: \_\_\_\_\_

#### CONFIGURATION:

- FIXED SPEED MOTOR GEAR REDUCER
- VARIABLE SPEED MOTOR GEAR REDUCER
- VARIABLE SPEED MOTOR + VFD

REDUCER MANUFACTURER: \_\_\_\_\_ GEAR RATIO: \_\_\_\_\_

REDUCER SERIAL NUMBER: \_\_\_\_\_ REDUCER MODEL: \_\_\_\_\_

MOTOR MANUFACTURER: \_\_\_\_\_ HORSEPOWER: \_\_\_\_\_

SPEED: \_\_\_\_\_ RPM VOLTS/PH/CY: \_\_\_\_\_ ENCLOSURE: \_\_\_\_\_

SPECIAL RATINGS: \_\_\_\_\_

LEAK DETECTOR: TYPE \_\_\_\_\_ MODEL \_\_\_\_\_

ACCESSORIES: \_\_\_\_\_

FLUID TO BE PUMPED: \_\_\_\_\_ OPERATING TEMPERATURE: \_\_\_\_\_ °F

DESIGN FLOW RATE: MIN \_\_\_\_\_ MAX \_\_\_\_\_

VISCOSITY (@PUMPING TEMPERATURE): \_\_\_\_\_ CPS

SOLIDS: - \_\_\_\_\_ % BY WT. PARTICLE SIZE: \_\_\_\_\_

DESIGN DISCHARGE PRESSURE: \_\_\_\_\_ PSIG MAX DESIGN PRESSURE: \_\_\_\_\_ PSIG

MINIMUM WORKING SPEED: \_\_\_\_\_ RPM MAXIMUM WORKING SPEED: \_\_\_\_\_ RPM

## **INSTRUCTION MANUAL**

This manual forms an integral part of the pump and must accompany it until its demolition. The series AMP peristaltic pump is a machine destined to work in industrial areas and as such the instruction manual must form part of the legislative dispositions and the applicable technical standards and does not substitute any installation standard or eventual additional standard.

### **GENERAL SAFETY WARNING**

Pumps are machines that can present dangers due to their operating under pressure and containing numerous moving parts.

- Improper use
- Removing the protections and/or disconnecting the protection device
- The lack of inspections and maintenance

### **CAN CAUSE SERIOUS DAMAGE OR INJURY**

The person in charge of safety should therefore guarantee that

- The pump is transported, installed, put in service, used, maintained and repaired by qualified personnel who should possess:

- Specific training and sufficient experience.
- Knowledge of the technical standards and applicable laws.
- Knowledge of the general national and local safety standards and also of installation.

Any work carried out on the electrical part of the pump should be authorised by the person responsible for safety. Given that the pump is destined to form part of an installation, it is the responsibility of whoever supervises the installation to guarantee absolute safety, adopting the necessary measures of additional protection.

**INDEX**

---

	Page number
• Equipment Identification	01
• Cover	02
• Index	03
• Transport and storage	04
• General safety standards	05
• General description	07
• Installation	08
• Check before start-up	09
• Maintenance	10
• Removing the hose – Disassembly	10
• Installing the hose – Assembly	10
• Removing and Installing the Rotor Assembly	11
• Troubleshooting	12
• Diagram of components parts	13
• Spare parts code	16
• Model number convention	17
• Warranty	18

## TRANSPORT AND STORAGE

### TRANSPORT

- The pump is protected by cardboard packaging.
- The packaging materials are recyclable.
- During transportation, the pump is in a resting position (the hose is not compressed)

### STORAGE

- The pump should be in a resting position. (The hose should not be compressed).
- Avoid areas open to inclement weather or excessive humidity.
- For storage periods of longer than 60 days, protect the coupling surfaces (clamps, reducers, and motors) with adequate anti-oxidant products.
- Pipe spares should be stored in a dry place away from direct light.

## SAFETY STANDARD



WARNING!

- Instructions of this manual that may compromise safety standards are identified by this symbol.
- Instructions of this manual that may compromise electrical safety are identified by this symbol.
- Instructions of this manual that may compromise the proper operation of the pump, are identified with this symbol.



Do not start the pump without first having installed the front cover.



For any operation of the equipment, it is necessary to make certain that the pump is stopped and the electrical supply disconnected.



Changing the hose should be done with the pump stopped.

WARNING!

Do not exceed the nominal pressure, speed or temperature of the pump, or use the pump for applications other than that originally planned without first consulting the manufacturer.

### CHARACTERISTICS FOR CONTINUOUS SERVICE

Hose Material	Temp.Min.(°F)	Temp.Max.(°F)	Pressure Max. (psi)
Natural Rubber	-4	175	115
Buna	14	175	115
EPDM	14	175	115
NORPRENE	-4	265	30
PHARMED	-4	265	30

WARNING!

Cleaning the pump, including the hose, should be done with fluids compatible with the construction of the pump and hose, and in accordance with recommended maximum temperatures.

WARNING!

Do not start the pump without it being properly secured to the floor.



Do not attempt to carry out any maintenance operations or dismantle the pump without first making sure that the pipes are not under pressure and are empty or isolated by proper valving.



The start system of the motor should be provided with a direction inverter, stop-go button and emergency stop button (together with the pump), in such a way that the pump can be operated with total safety.



In the case of the hose becoming stuck during removal or installation it is recommended to reverse the direction of the pump, relubricate, and then repeat the operation.



Peristaltic pumps are positive displacement devices capable of generating high pressures. To prevent a possible overload of pressure, due to for example, the accidental closure of a valve. It is advisable to fit a safety device such as a safety valve or other pressure-limiting device in the discharge piping.



Check the direction of rotation of the pump, as it is reversible it could generate pressure in the suction and compromise the safety of the installation. The circulation of the fluid should be in the same direction as the turning direction of the pump as seen from the inspection plate situated on the front cover.



The durability of the hose may vary due to operating conditions, so the possibility of a rupture and subsequent leakage of the fluid should be anticipated. The (optional) hose leakage detection probe can be interlocked to stop the pump and/or actuate isolation valve and/or alarm.

**GENERAL DESCRIPTION****PERISTALTIC PUMP****• Construction of the pump.**

As shown in the figure below, the pump unit is a very simple design, robust and with very few moving parts.

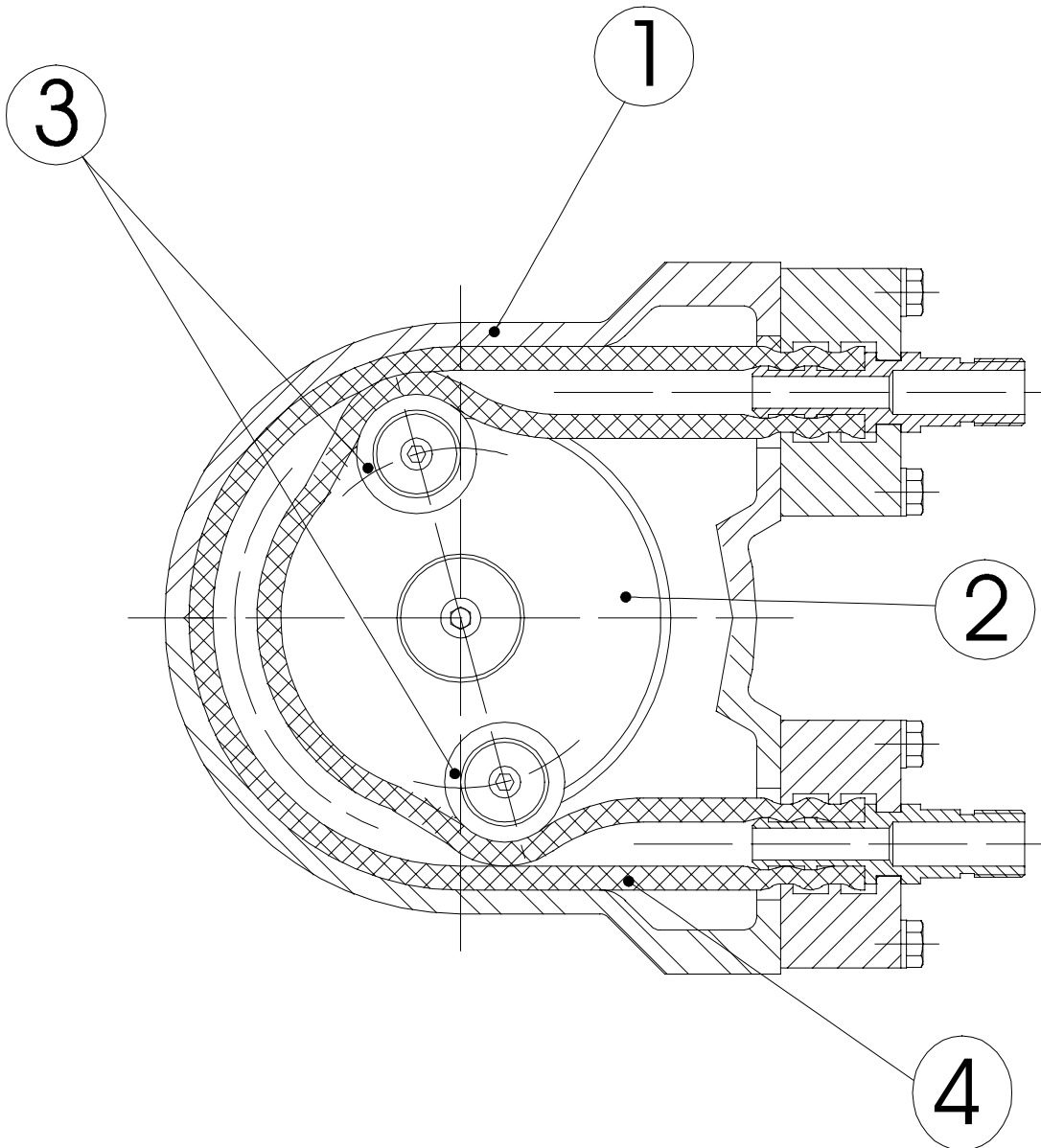

The outer casing (item 1) terminates with threaded connectors. Inside the casing are found the rotor (item 2), complete with two rollers with bearings (item 3). As the rotor turns, the rollers compress the reinforced hose/tube (item 4) generating a pumping action. A change in the direction of rotation will result in a change in direction of the pumped fluid.

## **INSTALLATION**

- Installation should normally be made in a well ventilated area away from heat sources. If it is necessary to place the pump outside it should be provided with a cover to protect it from sunlight and inclement weather.
- The positioning of the pump should allow easy access for all kinds of maintenance operations.

### **Piping: Correct installation.**

#### **Suction:**

- The pump should be located as near as possible to the supply of liquid so that the suction pipe is as short and straight as possible. The suction pipe should be perfectly airtight and made of suitable material so that it does not collapse due to the internal vacuum.
  - The minimum diameter should be similar to that of the hose/tube element.
  - With viscous fluids a larger diameter is recommended.  
(Consult manufacturer or distributor).
  - The pump has automatic suction and does not need an inlet valve.
- The pump is reversible, so the suction and discharge connections are interchangeable.  
(The pump is normally piped in a manner that best adapts to the physical installation)
- It is recommendable to use a flexible connection between the piping and the pump in order to avoid the transmission of vibration to the piping.

#### **Discharge:**

- To reduce power requirements, use the straightest and shortest piping possible. The diameter should be the same as the nominal diameter of the pump, except where precise calculations of piping losses have been performed.
  - With viscous fluids a larger diameter is needed.  
(Consult the manufacturer or distributor).
- Connect the fixed piping to the pump with a length of flexible pipe to facilitate maintenance, reduce vibrations and relieve piping stress on the pump. Fix the piping firmly.
- The discharge will pulse: To avoid such effect, it is advisable to install adequate pulsation dampeners.  
(See accessories.)

## **CHECKS BEFORE SWITCHING ON THE PUMP**

- Check that the pumping equipment has not suffered any damage during transportation or storage, any damage should be notified to the supplier immediately.
  
- Check that the supply voltage is suitable for the motor.
  
- Make sure that the hose is suitable for the fluid to be pumped, that it will not be chemically affected and that the temperature of the fluid does not exceed that recommended.
  
- **Hose:** If the hose is in a resting position, then the pump has come from storage or transportation; now is the time to install the second roller. **Do not switch on the pump without the pump body cover being correctly installed.**
- **Rotor:** Check that the roller shafts are correctly installed. For hose working pressures up to 60 psi (position 4), or thermoplastic tube (Norprene, Tygon, and Pharmed) operations up to 30 psi (position 2), the two mounting holes are marked with an indentation. The other two holes are unmarked and are suitable for hose working pressures from 60 to 115 psi (position 8).
- **Lubrication:** Check that the hose/tube surface and the surface of the rollers are correctly greased. The specially formulated grease can be obtained from PERIFLO or from the authorised distributor.

Check that the protectors of the moving parts are correctly assembled.

Check that the thermal protector corresponds with that of the values on the plate on the motor.

Check that the direction of rotation is the desired one. (rotation test).

Check that the optional electrical components are connected to the control panel and test that they function correctly.

Check that a proper pressure gauge is installed in the discharge. If the application involves a highly viscous fluid or long suction piping, it is recommended that a proper absolute-pressure gauge be installed in the suction.

Check predicted working conditions to verify that flow, pressure, temperature and motor power correspond to the project.

## **MAINTENANCE**

Any work carried out on the pump must be done when the pump is stationary and disconnected from the electrical supply.

### Lubrication

Check that the hose/tube and roller surfaces are correctly greased. Add lubricant as necessary. Recommend clear Silicon grease (or other suitable lubricant) that will not damage rubber parts.

The gearbox is lubricated and sealed for life. No routine maintenance or lubrication is required.

## **REPLACING THE HOSE – DISASSEMBLY** (refer to view on Page 14)

- Isolate the pump - all valves must be closed to prevent losses of the product.
- Disconnect the suction and discharge piping.
- Dismantle the suction/discharge hose/tube collars (item 11).
- Remove the front cover plate.
- Remove the rollers by first removing the roller that is not in contact with the hose/tube. Rotate the pump until the second rotor is not contacting the hose/tube and remove the second rotor.
- Remove the tube to be replaced and separate the inserts (item 10).

## **INSTALLING THE HOSE - REASSEMBLY**

- Clean the internal surfaces of the pump body.
- Inspect the rollers and roller shafts, checking that there is no damage to the pressure surfaces and that the rollers turn freely. If the pump is being set up for the first time, see paragraph Rotor in the section CHECKS BEFORE SWITCHING ON THE PUMP.
- Install the connecting inserts into each hose end.
- Install the hose in the pump body, lubricating the body, the hose, the roller shafts, and the surface of the rollers with grease. Recommend clear Silicon grease (or other suitable lubricant) that will not damage rubber parts.
- Install the tightening collars that fasten the hose and its connections to the pump body.
- Install the rollers. (refer to removal procedure above)
- Install the front cover.
- Install suction and discharge piping.

## **Removing and Installing the Rotor/Rotor Shaft and Rotor Shaft Seals**

- Remove the screw securing the rotor to the gearbox shaft (item 17), the washer and the front shaft seal gasket. Carefully slide the rotor off of the shaft. (this is a keyed shaft connection) Threaded jacking holes are provided in the rotor to assist in this operation.
- The rotor shaft seal o'ring and the rear shaft seal gasket can now be accessed for removal, inspection and replacement as necessary. Lubricate the o'ring liberally with silicon grease prior to reinstalling. The seal carrier can be inspected, removed and/or replaced as necessary by pressing from the housing.
- Rotor shafts can be removed by removing the rear retaining nut and pressing the shaft out of the rotor. Reinstall by pressing the shaft through the rotor and securing with the retaining nut.
- Insure that the rear shaft seal gasket and rotor shaft seal are properly installed. Lubricate the shaft with silicon grease and carefully slide the rotor onto the gearbox shaft, making sure that the keyway is properly aligned. Replace the front shaft seal gasket, washer and retaining screw.

## 5.3. PROBLEMS, CAUSES AND SOLUTIONS

PROBLEM	POSSIBLE CAUSE	SOLUCIÓN
<b>Elevated temperature</b>	Hose with no lubricant Elevated temperature of product Poor suction conditions  Rollers not turning properly  Excessive pumping speed	Use special lubricant from PERIFLO Reduce pumping temperature Check for obstructions Recalculate sections and lengths Check rollers shaft mounting  Reduce velocity of pump
<b>Reduction of capacity/pressure</b>	Suction or discharge valve closed. Hose insufficiently compressed  Rupture of the hose (the product leaks to the casing) Partial obstruction of suction piping Insufficient product amount in suction reservoir Insufficient diameter of suction piping Excessive length of suction pipe High viscosity of product  Entry of air via the suction connections High pulsation on suction	Open valves Check rollers shaft mounting  Replace drive hose Clean piping Fill or stop Increase pipe size/reduce pump speed Shorten suction piping Reduce viscosity Increase diameter of piping Confirm that the pump is suitable  Tighten connections and accessories Mount antipulsation equipment Reconsider application (speed etc.)
<b>Vibrations in pump and piping</b>	The piping is not correctly fixed together Excessive pumping speed  Insufficient diameter of piping Baseplate of pump loose Elevated pulsation of pump	Refix piping Reduce the speed of the pump  Increase pipe diameter Anchor the baseplate firmly Install pulsation dampening equipment in suction and/or discharge piping
<b>Short life of the hose</b>	Chemical attack  High speed of pump High pumping temperature High working pressure  Abnormal elevation of temperature Unsuitable lubricant Insufficient quantity of grease Cavitation of the pump	Confirm compatibility of the hose with the pumped fluid and the cleaning fluid Reduce speed of pump Reduce temperature of product Reduce speed of pump Increase discharge pipe size Check rollers shaft mounting/lubrication Use lubricant from PERIFLO Top up lubricant Reconsider suction conditions
<b>Stretching of the hose inside the pump</b>	Insufficient grease High suction pressures (>40 psi) Hose full of sediment Brackets insufficiently tightened	Top up lubricant Reduce suction pressure Clean hose Retighten brackets
<b>The pump does not start</b>	Insufficient starter power Insufficient power from frequency convertor  Blockage in the pump	Increase starter power Increase power Check that the voltage is adequate Do not drop below a frequency of 10Hz (confirm this point with the distributor) Start up will require at least 10Hz. Check there are no obstructions in the pipe

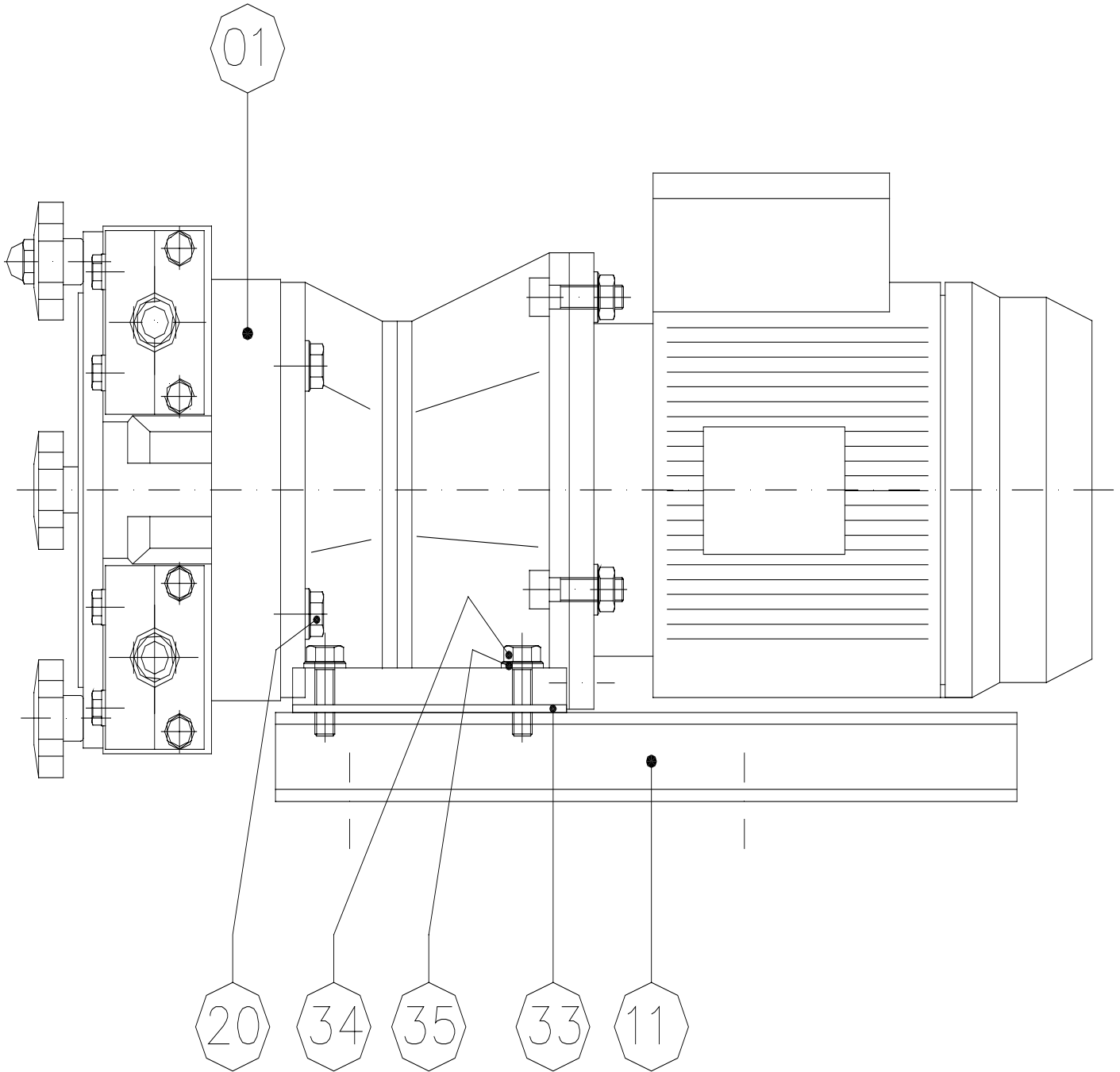

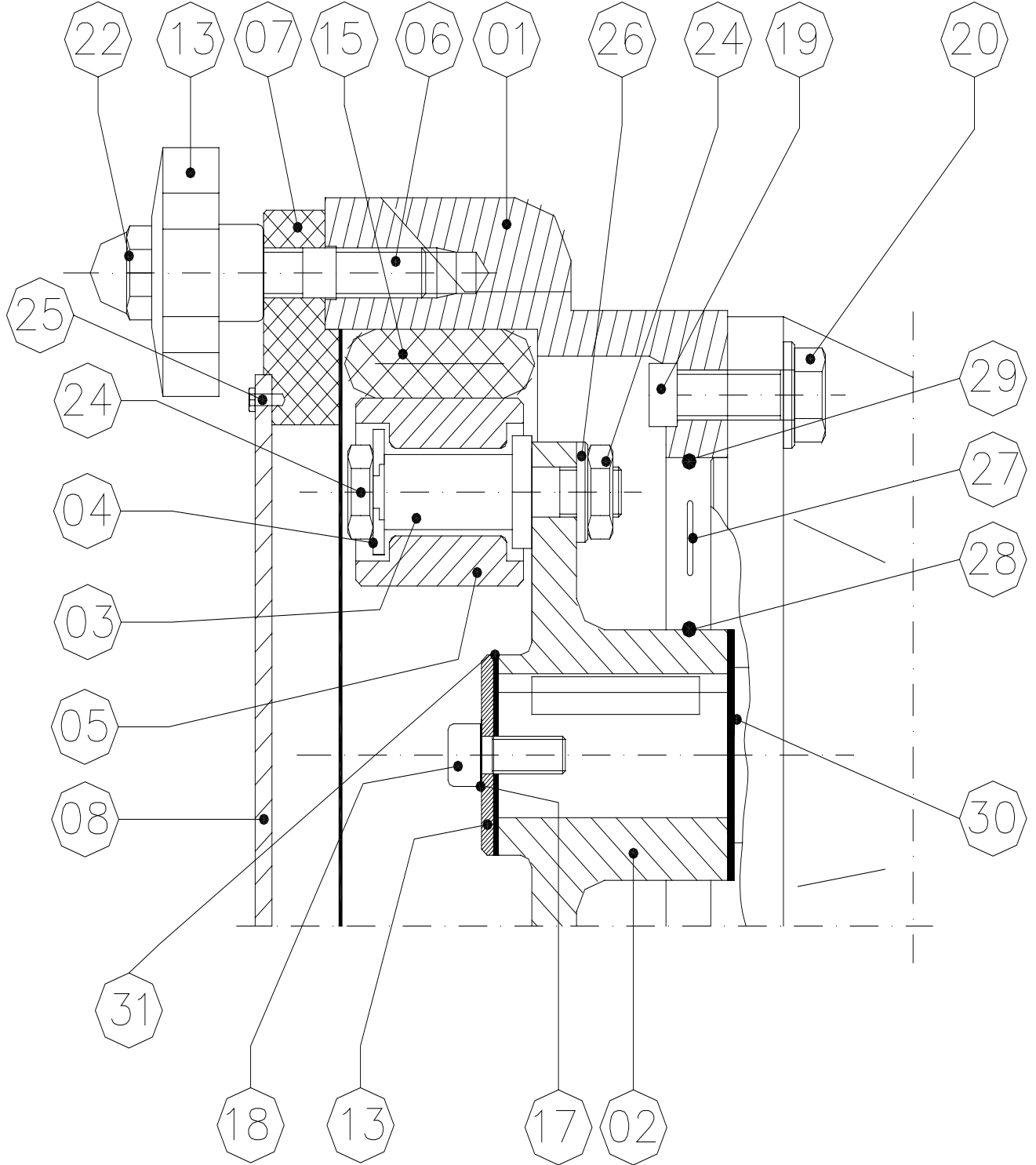

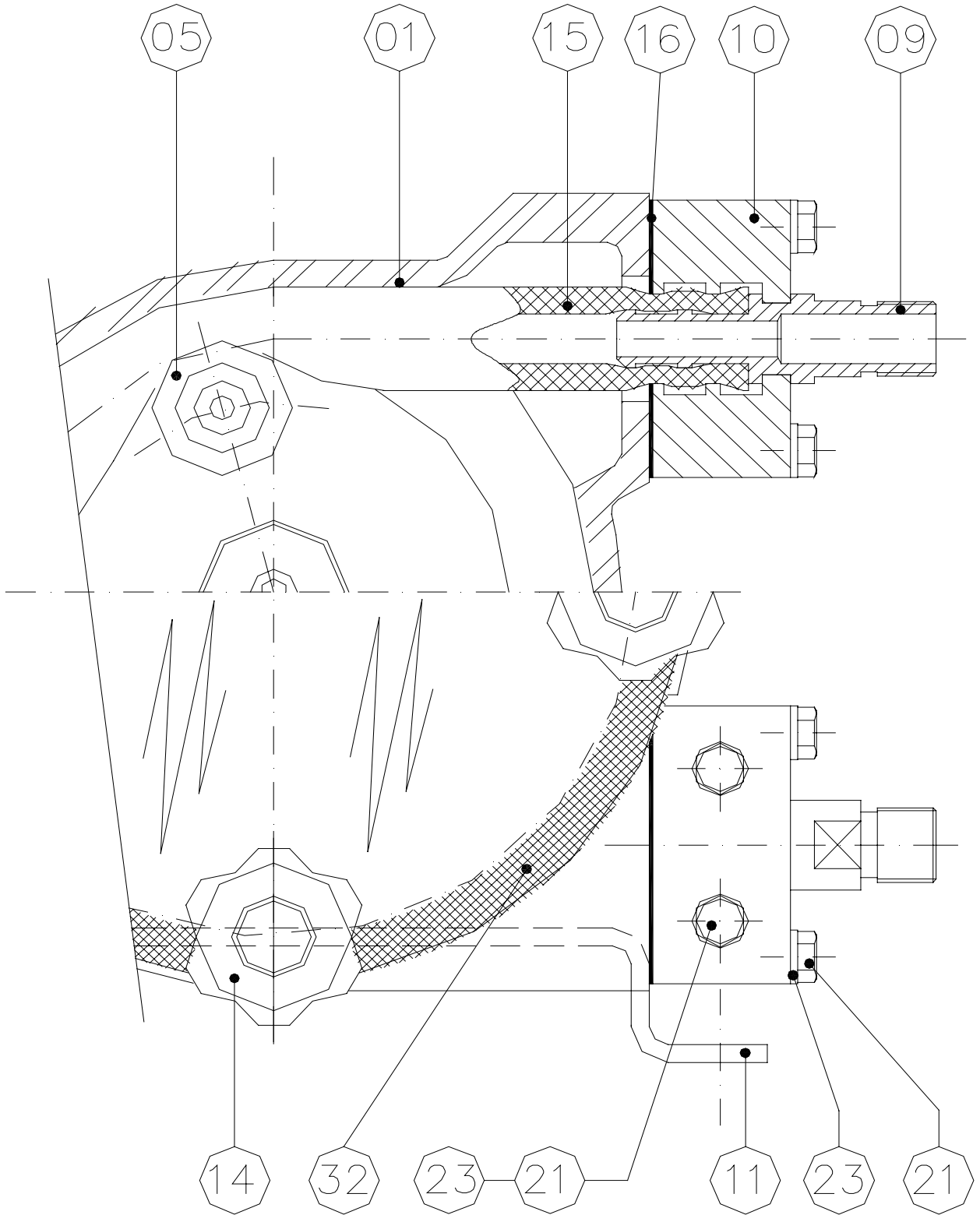

POS	DESCRIPTION	QTY	AMP-16CT	AMP-19CT	MATERIAL
			CODE	CODE	
1	Casing	1	101.00.01CT	101.00.01CT	Halar Coated AL
2	Rotor (2-roller)	1	101.00.13CT	101.00.13CT	Halar Coated CS
	Rotor (3-roller)	1	101.00.13CT3	101.00.13CT3	Halar Coated CS
3	Roller shaft	2	101.00.04SS	101.00.04SS	316SS
4	Thrust washer (D12)	2	101.00.05SS	101.00.05SS	316SS
5	Roller D42 - Hose	2	101.00.07D	N/A	Delrin
	Roller D50 - Tube	2	101.00.08D	N/A	Delrin
	Roller D48 - Tube	2	N/A	105.00.07D	Delrin
6	Long stud	1	102.00.07	102.00.07	304SS
	Short stud	3	102.00.14	102.00.14	304SS
7	Front Cover Ring	1	101.00.11CT	101.00.11CT	Halar Coated AL
8	Front Cover	1	101.00.12	101.00.12	Polycarbonate
9	Connections SS-NPT	2	101.00.16	101.00.16	316SS
	Connections PVC-NPT	2	101.00.17	101.00.17	PVC
	Connections PVDF-NPT	2	101.00.18	101.00.18	PVDF
	Connections TRI-CLAMP	2	101.00.21	101.00.21	316SS
10	Press flange - Hose	2	101.00.22CT	N/A	Halar Coated CS
	Press flange - Tube	2	101.00.23CT	101.00.22CT	Halar Coated CS
11	Baseplate SS	1	101.00.25EXT	101.00.25EXT	316SS
12	Rotor Washer	1	102.00.13SS	102.00.13SS	316SS
13	Cover press pommel	1	102.00.25	102.00.25	Nylon
14	Cover press pommel(blind)	3	102.00.26	102.00.26	Nylon
15*	Natural Rubber Hose	1	101.00.26	N/A	NR
	Buna Hose	1	101.00.27	N/A	BN
	EPDM Hose	1	101.00.28	N/A	EP
	Tygon Tube	1	101.00.29	105.00.26	TY
	Norprene Tube	1	101.00.30	105.00.27	E1
16	Connection Gasket	2	102.99.23	102.99.23	EPDM
17	Sealing Washer, ½" od	1	102.00.68	102.00.68	304SS/Neoprene
18	SS Bolt (M6x16)	1	102.99.02	102.99.02	304SS
19	SS Soc. Head Cap Screw (M8x30)	4	102.99.26	102.99.26	304SS
20	SS Flange Nut (M8)	4	102.99.99	102.99.99	304SS
21	SS Bolt (M8x45)	4	102.99.27	102.99.27	304SS
22	SS Acorn nut (M8)	1	102.99.06	102.99.06	304SS
23	SS Washer (M8)	8	102.99.07	102.99.07	304SS
24	SS Nylok Nut (M10)	2	101.00.33	101.00.33	304SS
25	SS Screw (M5 x 10)	2	102.99.09	102.99.09	304SS
26	SS Washer (M10)	2	102.99.27	102.99.27	304SS
27	Seal Carrier	1	101.00.60	101.00.60	PVC
28	O'Ring (Inner)	1	102.00.67	102.00.67	EPDM
29	O'Ring (Outer)	1	102.00.62	102.00.62	EPDM
30	Gasket – Rear Shaft Seal	1	102.00.63	102.00.63	PTFE
31	Gasket – Front Shaft Seal	1	102.00.64	102.00.64	PTFE
32	Gasket - Cover	1	102.99.21	102.99.21	EPDM
33	Shim	2	102.00.66	102.00.66	304SS
34	SS Bolt (5/16" x 1")	4	102.99.28	102.99.28	304SS
35	SS Washer (5/16")	4	102.99.29	102.99.29	304SS

*	Grease Lube (Food Grade)	3 oz	102.99.12	102.99.12	Silicon
*	Recommended Spare Parts				

<b>PERIFLO CHEMTUFF SERIES - COMPLETE PUMP MODEL NUMBER</b>	
<b>POS 1 + POS 2 + POS 3 + POS 4 + POS 5 + POS 6 + POS 7 + POS 8 + POS 9 + POS 10</b>	
<b>POS 1 - PUMP SERIES</b>	<b>POS 6 - SPEED</b>
CT10H - CT10 for HOSE	000 - BARE PUMP
CT10T - CT10 for TUBE	___ - SPECIFY 3 DIGIT SPEED
CT13H - CT13 for HOSE	(EXAMPLE 020 for 20 RPM)
CT13T - CT13 for TUBE	SEE PRICE LIST FOR STANDARD SPEEDS
CT16H - CT16 for HOSE	
CT16T - CT16 for TUBE	<b>POS 7 - HORSEPOWER</b>
CT19T - CT19 for TUBE	X - NONE
CT22H - CT22 for HOSE	A - 0.25 HP
CT22T - CT22 for TUBE	B - 0.33 HP
	C - 0.50 HP
<b>POS 2 - HOSE/TUBE MATERIAL</b>	D - 0.75HP
NR - NATURAL RUBBER HOSE	E - 1.00 HP
BN - BUNA HOSE	F - 1.50HP
EP - EPDM HOSE	
HY - HYPALON HOSE	<b>POS 8 - MOTOR ENCLOSURE</b>
NF - NATURAL RUBBER HOSE (FD. GR.)	00 - NONE (NEMA GEARBOX INPUT)
BF - BUNA HOSE (FD. GR.)	T1 - TEFC 115/208/1/60
E1 - NORPRENE TUBE (FDA, 3A)	T3 - TEFC 230/460/3/60
PH - PHARMED TUBE (FDA, USP)	X1 - EXPLOSION PROOF 115/208/1/60
TY - TYGON TUBE (CT16 & 19 ONLY)	X3 - EXPLOSION PROOF 230/460/3/60
	TV - TENV 230/460/3/60 CHEM DUTY
<b>POS 3 - DISCHARGE PRESSURE</b>	VS INVERTER DUTY 1000:1 TURNDOWN
2 - 30 PSI (TUBE)	XV - VS EXPLOSION PROOF 230/460/3/60
8 - 116 PSI (HOSE)	INVERTER DUTY 1000:1 TURNDOWN
	W1 - TENV WASHDOWN 230/460/3/60
<b>POS 4 - INSERTS</b>	WV - TENV WASHDOWN VS 230/460/3/60
S - 316 STAINLESS MNPT	10:1 TURNDOWN
C - PVC CAMLOK	
V - PVC MNPT	<b>POS 9 - SPECIAL</b>
P - POLYPROPYLENE MNPT	3R - 3 ROLLERS
K - PVDF (KYNAR) MNPT	XD - OTHER SPEEDS
T - 1/2" TRI-CLAMP (AMP10,AMP13)	
T - 3/4" TRI-CLAMP (AMP16)	
T - 1" TRI-CLAMP (AMP19)	<b>POS 10 - ACCESSORIES</b>
	VS1 - VARIABLE FREQUENCY DRIVE NEMA 1
<b>POS 5 - SUCTION/DISCHARGE ORIENTATION</b>	VS4 - VARIABLE FREQUENCY DRIVE NEMA 4
A - RIGHT (Standard)	VS4X - VARIABLE FREQUENCY DRIVE NEMA 4X
B - DOWN	LD1 - LEAK DETECTOR AMP16/19/22 *
C - LEFT	LD2 - LEAK DETECTOR AMP10/13 *
D - UP	TAC2 - SPEED TACH RING W/ PULSE OUTPUT
	* CAPACITANCE TYPE

**WARRANTY**

- Periflo warrants its equipment against all defects in materials, manufacturing and workmanship for one year from the date of delivery. This warranty does not include normal wearing items such as the hose or lubricant since their life is highly dependent on the specific operating conditions of the application and installation.
- This warranty is valid as long as the equipment functions within the parameters indicated in the technical information card supplied with every pump or on subsequent changes authorised by PERIFLO.
- This warranty includes materials and labor only, and does not include transportation of materials to or from our warehouses in Loveland, Ohio, Transportation charges will be the responsibility of the customer.